

**SAMPLE QUESTION PAPER**  
**PHYSICS (THEORY)**  
**CLASS XII**  
**BOARD/ PRE-BOARD EXAMINATION (2020-21)**

**Time: 3 Hour 15 Minutes.**

**Maximum Marks: 70**

**General Instructions:**

1. All questions are compulsory. There are **37 (Thirty Seven)** questions in all.
2. This question paper has four Sections: Section **A**, Section **B**, Section **C**, and Section **D**.
3. Section **A** contains **20(Twenty)** questions of **one** mark each, Section **B** contains **7(Seven)** questions of **two** marks each, Section **C** contains **7(Seven)** questions of **three** marks each and Section **D** contains **3(Three)** questions of **five** marks each.
4. There is no overall choice. However, internal choices have been provided in **2(Two)** questions of **one** mark, **2(Two)** questions of **two** marks, **1(One)** question of **three** marks and all the **3(three)** questions of **five** marks. You have to attempt only one of the choices in such questions.
5. You may use the following values of physical constants wherever necessary:

$$c = 3 \times 10^8 \text{ m s}^{-1}$$

$$h = 6.63 \times 10^{-34} \text{ J s}$$

$$e = 1.6 \times 10^{-19} \text{ C}$$

$$\mu_0 = 4\pi \times 10^{-7} \text{ T m A}^{-1}$$

$$\epsilon_0 = 8.854 \times 10^{-12} \text{ C}^2 \text{ N}^{-1} \text{ m}^{-2}$$

$$\frac{1}{4\pi\epsilon_0} = 9 \times 10^9 \text{ N m}^2 \text{ C}^{-2}$$

$$\text{Mass of electron} = 9.1 \times 10^{-31} \text{ kg}$$

$$\text{Mass of proton} = 1.673 \times 10^{-27} \text{ kg}$$

$$\text{Mass of neutron} = 1.675 \times 10^{-27} \text{ kg}$$

$$\text{Avogadro's number} = 6.023 \times 10^{23} \text{ per gram mole}$$

$$\text{Boltzmann constant} = 1.38 \times 10^{-23} \text{ J K}^{-1}$$

**SECTION-A**

*Select the most appropriate option from those given below each question for question number 1 to 10:*

1. The electric field lines of an isolated positive point charge are 1  
i) clockwise,                      ii) anti-clockwise,  
ii) normally outward,              iv) normally inward.
  
2. Lengths of two copper wires are 1 m and 4 m respectively but their resistances are same. The ratio of their diameter is 1  
i) 2 : 1,      ii) 1 : 2,      iii) 4 : 1,      iv) 1 : 4,

3. Phase difference between two coherent source is 1  
 i) 0, ii)  $\pi/2$ , iii)  $\pi$ , iv) none of these.
4. If the kinetic energy of a free electron doubles, its de-Broglie wave length changes by a factor 1  
 i) 2, ii)  $\frac{1}{2}$ , iii)  $\sqrt{2}$ , iii)  $\frac{1}{\sqrt{2}}$ .
5. A photon beam of energy 12.1 eV is incident on a hydrogen atom. The orbit to which the electron of hydrogen atom be excited 1  
 i) 2<sup>nd</sup>, ii) 3<sup>rd</sup>, iii) 4<sup>th</sup>, iv) 5<sup>th</sup>.

**Question no. 6 to 10: Fill in the blanks with suitable word(s):**

1. Kirchoff's junction rule is based on conservation of \_\_\_\_\_ . 1  
 OR,  
 Potentiometer is unaffected by the \_\_\_\_\_ of the voltage source being measured.
2. Two thin lenses of focal lengths  $f_1$  and  $f_2$  are separated by a distance  $d$ . If the power of the lens combination is zero, then the value of  $d$  should be \_\_\_\_\_ . 1
3. In a single slit diffraction the width of the slit is made double the original width. The intensity of the central diffraction band will be \_\_\_\_\_ times its initial intensity. 1
4. The photo electric cut-off voltage in a certain experiment is 1.5 eV. The maximum kinetic energy of the emitted photoelectrons is \_\_\_\_\_ . 1
5. The energy equivalent of 1 g of substance is \_\_\_\_\_ . 1
6. If a hollow sphere of radius  $r$  is given a charge  $q$  then what will be the electric potential and field inside the sphere? 1
7. An electron enters perpendicularly into a magnetic field of 0.4 T with a velocity  $5 \times 10^4 \text{ m s}^{-1}$ . What is the magnitude of the force experienced by the electron? 1
8. What are the angles of dip at the earth's magnetic equatorial plane and at the north pole? 1
9. The current flowing in two coils of self-inductances  $l_1 = 16 \text{ mH}$  and  $l_2 = 12 \text{ mH}$  are increasing at the same rate. If the powers supplied to the two coils are equal, what will be the ratio of induced emf in the coils? 1

10. What is the average value of an a.c. over a complete cycle? 1
11. When light enters from a rarer to a denser medium, the speed decreases. Does the reduction in speed imply a reduction in the energy carried by the light wave? 1
12. What will be the nature of the final image formed in an astronomical reflecting telescope with respect to the object? 1
13. Two nuclei have mass numbers in the ratio 27:125. What is the ratio of their nuclear radii? 1
14. How does potential barrier change when a forward bias is applied to a p-n junction? 1
15. A p-n junction diode is fabricated from a semi conductor with band gap of 3.0 eV. Radiations of which wave lengths can be detect by it? 1
- OR,
- What is the current flowing through the following circuit? 1



### SECTION B

16. Show that electric field at any point is always perpendicular to the equipotential surface passing through that point? 2
17. Derive a relation between current density and drift velocity of electron. 2
18. An  $\alpha$ -particle and a proton are accelerated through same potential difference. Find the ratio  $\left(\frac{v_\alpha}{v_p}\right)$  of the velocities acquired by the two particles. 2
19. A region is illuminated by two sources of light. The intensity  $I$  at each point is found to be equal to  $I_1 + I_2$ , where  $I_1$  is the intensity of light at the point when source 2 is absent,  $I_2$  is similarly defined. Are the sources coherent or incoherent? Explain. 2

OR

In the Young's double slit experiment the path difference produced due to interference of yellow colour of light at a point on the screen be  $\lambda$ , what will be the colour of the fringe at that point if the slits are illuminated by (i) yellow light and (ii) white light? 1+1

20. A particle is moving 3 times as fast as an electron. The ratio of the de-Broglie wavelength of the particle to that of the electron is  $1.813 \times 10^{-4}$ . Calculate the particle mass and identify the particle.

$$1\frac{1}{2} + \frac{1}{2}$$

OR,

Suppose you are given a chance to repeat the  $\alpha$ -particle scattering experiment using a thin sheet of solid hydrogen in place of the gold foil (Hydrogen is a solid at temperature below 14 K). What results do you expect?

21. i) Find the relation between three wave lengths  $\lambda_1$ ,  $\lambda_2$  and  $\lambda_3$  from the energy level diagram shown below as  $E_{CA} = E_{CB} + E_{BA}$

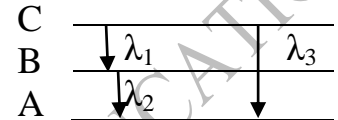

- ii) What will happen if an electron instead of revolving becomes stationary in an hydrogen atom?

1+1

22. In the following diagrams indicate which of the diodes are forward biased and which are reverse biased?

$$\frac{1}{2} \times 4$$

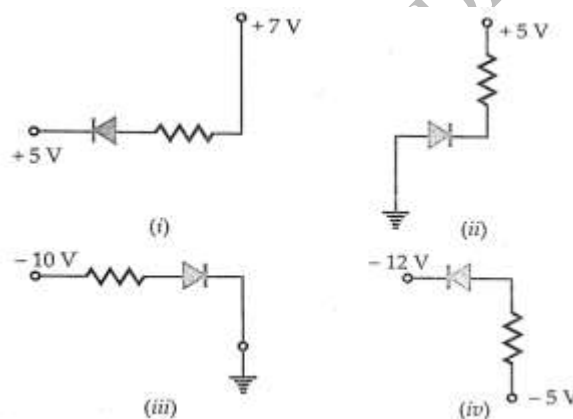

### SECTION C

23. A cylindrical wire has length  $L$  and cross-sectional area  $A$ . Its resistivity changes as  $\rho = \rho_0 x$ , where  $x$  is the distance from starting end. Find the resistance of the wire. Show graphically the variation of resistivity with temperature for copper wire.

2+1

24. Using Biot-Savart law, derive an expression for magnetic field at any point on axial line of a current carrying circular loop. Hence find magnetic field intensity at the centre of the circular loop.

$$2\frac{1}{2} + \frac{1}{2}$$

OR,

A coil with number of turns  $N$ , area  $A$  is rotated at a constant angular speed  $\omega$  in a uniform magnetic field  $B$  and connected to a resistor  $R$ . Deduce expression for (i) maximum emf induced in the coil, and

(ii) power dissipation in the coil.

$$2\frac{1}{2} + \frac{1}{2}$$

25. The teachers of Geeta's school took the students on a study trip to Dambur hydroelectric power generation station, located nearly 120 km away from the city Agartala. The teacher explained that electrical energy is transmitted over such a long distance to their locality, in the form of alternating current (ac) raised to a high voltage. At the receiving end in the locality, the voltage is reduced to operate the devices by using appropriate device. As a result power loss is reduced. Geeta listened to the teacher and asked questions about how the ac is converted to higher or lower voltage.

Answer the following questions on the basis of your understanding of the above paragraph and the related studied concept:

(i) Name the device used to change the alternating voltage to a higher or lower voltage at power generation centre and local power distribution centre.

(ii) Mention one cause for power dissipation in this device. How can it be minimized? 1+(1+1)

26. (i) Arrange the following electromagnetic waves in the descending order of their wavelengths- a) Microwaves, b)  $\gamma$ -ray and write one use of each of them.

(ii) Sketch a schematic diagram depicting oscillating electric and magnetic fields of an EM (electromagnetic) wave propagating along positive Z-direction. (1+1)+1

27. You are given a concavo-convex lens of material having refractive index 1.5 and three liquids A, B and C of refractive indices 1.43, 1.5 and 1.65 respectively.

(i) What will be the focal length of the lens, if it is immersed in the liquid of refractive index 1.5.

(ii) If the lens is immersed in the liquid A and C respectively, what will be the nature of the lens in each case?

(iii) The lens is now immersed in the liquid B. What will be the deviation of the ray incident at an angle  $40^\circ$  with the principal axis? 1+1+1

28. (i) Name the series of hydrogen spectrum lying in the ultraviolet region.

(ii) The ground state energy of hydrogen atom is -13.6 eV. What are the kinetic and potential energies of the electron in this state?

(iii) What are the kinetic and potential energies of the electron in the 3<sup>rd</sup> excited state? 1+1+1

29. (i) Why is a photodiode operated in reverse bias mode?

(ii) For what purpose is a photo-diode used?

(iii) Draw its I-V characteristics of a photodiode for different intensities.

1+1+1

## SECTION D

30. (i) Derive an expression for torque experienced by an electric dipole placed in a uniform electric field at an angle  $\theta$  with the direction of the field.
- (ii) A sphere is charged with +1 C charge. Calculate the number of electrons that shortage or surplus in the sphere .
- (iii) Four point charges  $q_a=2 \mu\text{C}$ ,  $q_b=-5 \mu\text{C}$ ,  $q_c=2 \mu\text{C}$  and  $q_d=-5 \mu\text{C}$  are located at the corners of a square ABCD of sides 10 cm . What is the force on a charge of  $1 \mu\text{C}$  placed at the centre of the square? 3+ (1+1)

OR,

- (i) Find the capacitance of a parallel plate capacitor.
- (ii) Find the ratio of the potential differences that must be applied across the parallel and series combination of two capacitors  $C_1$  and  $C_2$  with their capacitance in the ratio of 1:2 so that the energy stored in the two cases are same.
- (iii) What is quantization of charge? 2+ 2+1
31. (i) An a.c. source of voltage  $v=v_0\sin\omega t$  is connected across a series combination of an inductor, a capacitor and a resistor. Use the phasor diagram to obtain the expression for
- a) Impedance of the circuit, and
- b) Phase angle between the voltage and the current.
- (ii) In India the frequency of a.c. supply is 50 Hz. How many times the current changes its direction in one second?
- (iii) Draw a graph showing the variation of impedance with frequency of a.c. in series LCR circuit. Hence explain what happens when,  $\omega < \omega_r$ ,  $\omega = \omega_r$  and  $\omega > \omega_r$ ; where  $\omega_r$  is the resonant frequency.  $2 + \frac{1}{2} + (1 + \frac{1}{2} \times 3)$

OR,

- (i) Show that work done by a magnetic field on a moving charged particle is always zero.
- (ii) A magnetic field that varies in magnitude from point to point but has a fixed direction (east to west) is set up in a chamber. A charged particle enters the chamber and travels undeflected along a straight path with constant speed. What can you say about the initial velocity of the particle?
- (iii) A bi-cycle generator creates 3.0 V, when the bicycle is travelling at a speed of 9.0 km/hr. How much emf is generated when the bi-cycle is travelling at a speed of 15 km/hr?
- (iv) Find the magnetic field inside a toroid using Ampere's circuital law. 1+1+1+2

32. Draw ray diagram showing the image formation of a distant object by a refracting telescope. Define its magnifying power and write the expression for

it. Write two important limitations of a refracting telescope over a reflecting telescope.

$$1\frac{1}{2} + 1\frac{1}{2} + 2$$

OR,

- i) Derive lens maker's formula for convex lens. How can you obtain thin lens formula from it?
- ii) A small bulb is placed at a depth  $d$  in a tank full of a liquid of refractive index  $\mu$ . Show that the radius of the circular base of the cone at the surface of the liquid through which light can emerge out is  $r = \frac{d}{\sqrt{\mu^2 - 1}}$ . (2+1)+2

\*\*\*\*\*

TRIPURA BOARD OF SECONDARY EDUCATION